

DLR5040A-WE

■ Screw Fastening Counter

Features

For prevention of human fastening errors and enhanced fastening management accuracy

- Ideally suited for the assembly lines of vehicles and electrical equipment requiring reliable screw fastening
- The controller receives signals from electric screwdrivers to provide highly reliable screw fastening control
- Count Return Function: When a screw is loosened, a reverse signal output from the electric screwdriver reverses the count by one
- The Count Correction Function does not count elevated screws or double fastening
- Input voltage range from 100 to 240 V AC is acceptable in any part of the world (The screwdrivers to be used in combination with the counter require input power supplies that are written on the respective nameplate)
- Link Connection Function: You can build up a simple sequential screw tightening system by connecting the DLR5040A-WE screw tightening counters in series without using any external controller such as a programmable controller
- Driver Lock Function prevents unexpected start of screwdrivers
- Compact and Lightweight (Compared with our conventional models decreased by 30 % in volume and by 38 % in mass)
- SPC type screwdrivers for DLR5040A-WE are designed on the basis of established transformerless screwdrivers

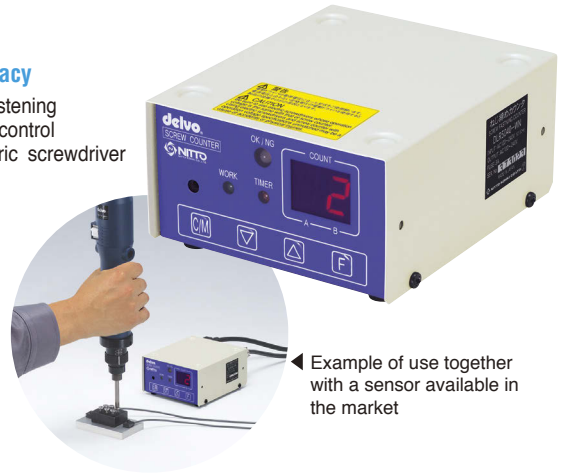

◀ Example of use together with a sensor available in the market

Specifications

Model	DLR5040A-WE
Count	1 - 99
Counting Method	Count-up / Count-down
Count Correction Function	Count normal fastening only
Self Adjustable Timer Setting	0.01 to 0.99 sec.
Work Detection Function	Yes (1 terminal) / No
External Count Input	2 terminals (PARTS A / PARTS B)
Work Installation Timer Setting	0 to 9.5 sec.
OK Output Timer Setting	0 to 9.5 sec.
NG Alarm	ON(1) / ON(2) / OFF
OK Buzzer	ON(1) / ON(2) / ON(3) / OFF
Count Return Function	ON / OFF
NG Judge Timing	WORK SET / DRIVER ON
Automatic / Manual OK Judge	AUTO / MANUAL
Screwdriver Lock Function	ON / OFF
Multiple Link	Up to 10 counters can be connected.
External Inputs on Terminal Block	SENSOR / RESET / LINK-IN / PARTS A / PARTS B
External Outputs on Terminal Block	OK / NG / LINK-OUT
Parameter Memory	Parameters stored in internal nonvolatile memory
Input Voltage	100 - 240 V AC, 50/60 Hz
External Dimensions (mm)	W100 × D120 × H60
Mass (kg)	0.47

Accessory : 2 m cord with UL three-prong plug. This product is for use outside Japan.

Front and Rear Panels

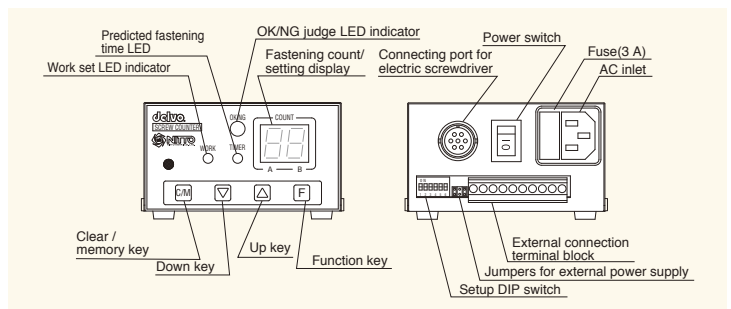

LINK Function

When counters are connected and activated in the screw fastening sequence as shown below, all screwdrivers are on standby except the first one in the sequence. Only when the first screw fastening is finished, can the next screwdriver change from standby to ready. When the last fastening in the sequence is finished, the first screwdriver is once again ready and the sequence can be repeated again.
N.B. Up to 10 screwdriver/counter sets can be connected to the LINK.

DLR5340-WE

■ Screw Fastening Counter

Features

Up to three sets screwdrivers can be connected to one counter

- Up to eight kinds of screw fastening conditions can be stored in internal memory for a wide variety of assembly work
- Count-up signal outputs
- Space saving
- The Count Correction Function does not count elevated screws or double fastening as fastening errors
- Count Return Function: When a screw is loosened, a reverse signal output from the electric screwdriver reverses the count by one

Specifications

Model	DLR5340-WE
Count	0 - 99
Counting Method	Count-up / Count-down
Count Correction Function	Count normal fastening only
Self Adjustable Timer Setting	0.01 to 2.50 sec.
Work Detection Function	Yes (1 terminal) / No
Work Installation Timer Setting	0 to 9.5 sec.
OK Output Timer Setting	0 to 9.5 sec.
NG Alarm	ON(1) / ON(2) / OFF
OK Buzzer	ON(1) / ON(2) / ON(3) / ON(4) / ON(5) / OFF
Count Return Function	ON / OFF
Screwdriver Lock Function	ON / OFF
Screwdriver Cord Connection	Single cord connection (Signal and power lines)
External Inputs on Terminal Block	SENSOR / RESET / TORQUE CHECK / ch1/2/3
External Outputs on Terminal Block	OK / NG / COUNT-UP / DRIVER A/B/C
Input Voltage	100 - 240 V AC, 50/60 Hz
External Dimensions (mm)	W150 × D120 × H60
Mass (kg)	0.62

Accessory : 2 m cord with UL three-prong plug. This product is for use outside Japan.

Front and Rear Panels

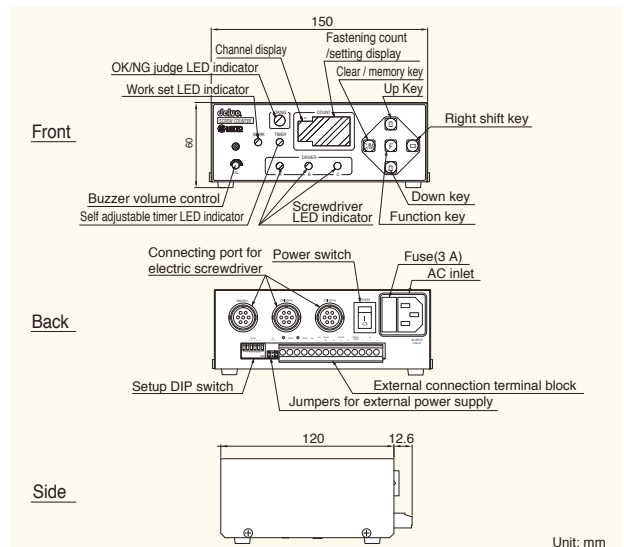

Unit: mm

Dedicated Screwdrivers for DLR5040A-WE and DLR5340-WE



DLV7000-SPC series



DLV8000-SPC series

Dedicated Screwdrivers

		Miniature Screw(1.0 - 3.5 mm)							
Electric Screwdriver	Model	Lever Start	DLV7020-SPC	DLV7030-SPC	DLV7031-SPC	DLV8020-SPC	DLV8030-SPC	DLV8031-SPC	
		Push to Start							
	Input Voltage		100 V AC, 50/60 Hz						
	Torque Adjustment		Stepless						
	Torque (Nm)		0.05 - 0.55	0.3 - 1.1	0.3 - 1.0	0.1 - 0.55	0.3 - 1.1	0.3 - 1.0	
	Free Speed (min ⁻¹)		900	650	1,200	900	650	1,200	
	Power Consumption (W)		Approx. 25		Approx. 30	Approx. 25		Approx. 30	
	Screw Size (mm)	Machine Screw		1.0 - 3.0	2.0 - 3.5	2.0 - 3.0	1.0 - 3.0	2.0 - 3.5	2.0 - 3.0
		Tapping Screw		1.2 - 2.6	2.0 - 3.0	2.0 - 3.0	1.2 - 2.6	2.0 - 3.0	2.0 - 3.0
	Bit Type (mm)								
Mass (g)		380			390				
Cord Length (m)		3 (with connector)							
Bit Grounding		Equipped as standard							

Optional Accessories



Torque Adjustment Cover
(DLW5200:DLV7100/7200/8100/8200-SPC
DLW5300:DLV7000/8000-SPC)

- Tampering or accidental turning of the torque adjustment cover by an operator can be prevented
- Flanged coupling DLW9011 can not be mounted on SPC type



Pistol Grip
(DLW2300:DLV7100/7200/8100/8200/30/45/70-SPC)

- Suitable for horizontal operation

TD04061 SPC cord for commercial power source (optional)



Dedicated screwdrivers can be directly plugged in commercial power source.



DLV7100/7200-SPC series



DLV8100/8200-SPC series



DLV7251-SPC



DLV8150/8251-SPC



DLV30LP-SPC



DLV30SP-SPC



DLV30HP-SPC



DLV45SL-SPC



DLV70LP-SPC

Dedicated Screwdrivers

		Machine Screw(2.6 - 8.0 mm)							Built-in brushless motor						
Electric Screwdriver	Model	Lever Start	DLV7120-SPC	DLV7130-SPC	DLV7140-SPC	DLV7251-SPC	DLV7241-SPC	DLV7231-SPC	DLV30LL-SPC	DLV30SL-SPC	DLV30HL-SPC	DLV45LL-SPC	DLV45SL-SPC	DLV70LL-SPC	
		Push to Start	DLV8120-SPC	DLV8130-SPC	DLV8140-SPC	DLV8150-SPC	DLV8251-SPC	DLV8241-SPC	DLV8231-SPC	DLV30LP-SPC	DLV30SP-SPC	DLV30HP-SPC	DLV45LP-SPC	DLV45SP-SPC	DLV70LP-SPC
	Input Voltage	100 V AC, 50/60 Hz *													
	Torque Adjustment	Stepless													
	Torque (Nm)		0.25 - 0.75	0.5 - 1.7	1.2 - 3.0	2.0 - 4.5	2.0 - 4.5	1.2 - 3.0	0.5 - 1.7	0.4 - 1.6/1.2 - 3.0			2.0 - 4.5	3.8 - 7.0	
	Free Speed (min ⁻¹)		1,000		700	450	700	1,200	2,000	650	1,200	2,000	650	1,200	650
	Power Consumption (W)		35					45							
	Screw Size (mm)	Machine Screw		2.6 - 3.0	2.6 - 4.0	3.5 - 5.0	4.5 - 6.0	4.5 - 6.0	3.5 - 5.0	2.6 - 4.0	2.6 - 5.0			4.5 - 6.0	5.0 - 8.0
		Tapping Screw		2.3 - 3.0	2.5 - 3.5	3.0 - 4.0	4.0 - 5.0	4.0 - 5.0	3.0 - 4.0	2.5 - 3.5	2.5 - 4.0			4.0 - 5.0	4.5 - 6.0
	Bit Type (mm)														
Mass (g)		710(7100series)/670(8100series)		810		710(7200series)/670(8200series)		700			870 with pistol grip				
Cord Length (m)		3 (with connector)													
Bit Grounding		Equipped as standard													

*Please contact us for other voltage availabilities.